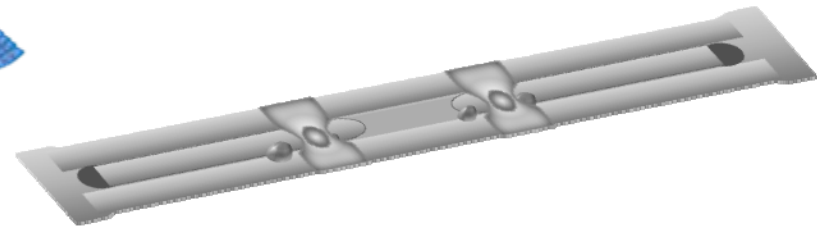
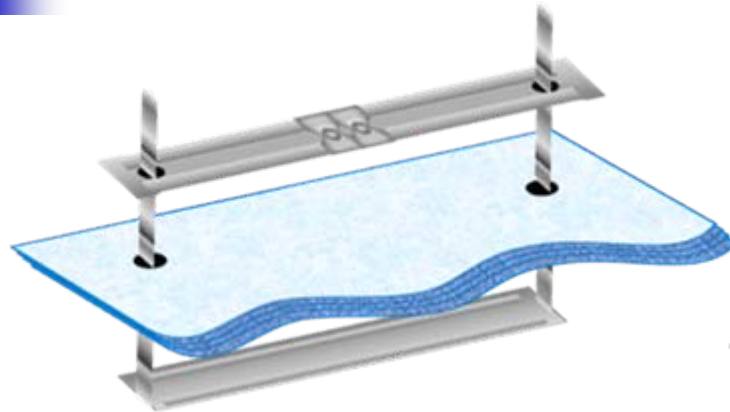


Application of USIT to Useful Paper Fastener



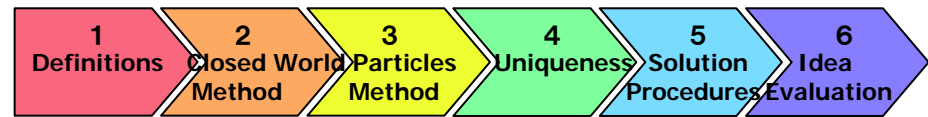
MPUF(Microsoft Project Users Forum)

USIT/TRIZ Study Group Paper Fastener Working Group members

Kouichi Nakamura (USIT/TRIZ Study Member),
Hirotake Makino (USIT/TRIZ Study Member),
kazushige Aoki (USIT/TRIZ Study Member),
Etsuo Yamada (USIT/TRIZ Study Member)
Tatsuhiko Atsuta (Hitachi Maxell, Ltd)
Yuji Mihara (Creative Technology Institute Co. Ltd.)

Noritaka Nakayama (Konica Minolta Technology Center, Inc.),
Hideki Ohmori (USIT/TRIZ Study Member),
Kazunori Aoki(Tokyo Keiki Kogyo Co., Ltd.)
Minoru Takimoto (Fuji Xerox Corporation),
Osamu Kumasaka (Kumasaka Professional Engineer office)

USIT Approach



1. Problem Definition

Well-defined USIT Problem (Root causes analysis)

2. Closed World Method

Analysis from existing minimum sets of objects
CW-diagram → Qualitative-Change Graph (→O-A Matrix Chart)

3. Particles Method
(Ideal Model Method)

Analysis from Ideal Solution Back to its unwanted effect
Morph cartoon → Action & Property Diagram (AND OR Tree)

4. Uniqueness

Examine Temporal & Spatial Uniqueness

5. Solution Procedures

Primary STEP

Secondary STEP

Object
Pluralization

Attribute
Dimensionality

Function
Distribution

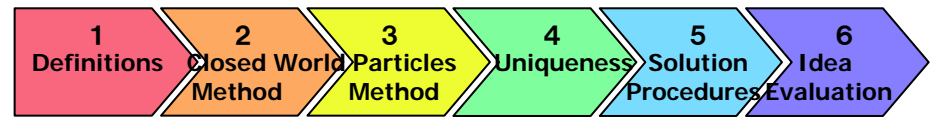
Generalization-type solution

Solution Combination

6. Evaluation

Evaluate the Ideas

USIT Approach



The entire procedure was followed to the fifth symposium that had been reported last year.

That is: J16 「USIT Workbook for IT & Software Engineer」 T. Maeda et.al. [USIT/TRIZ Study Group, MPUF]

We have referred not only the work procedure but also the note.

Example of USIT Workbook

1. Problem Definition

Purpose : Define the problem to solve , Clarify by making statement and it agrees among members.

It thinks freely by excluding the restriction of the ready-made technology and resource.

It thinks about the cost and the delivery date by "Ch6 :Idea Estimation"

Note

- The problem to be solved is clarified. It writes as a 「 problem. issues」
“Desire Effect “turns over the expression that is, expresses “Un desire effect “expression.
- The most important problem should be selected when there are two or more problems to be solved.
- When multiple people such as working group attempt solving the problem, and mutual agreement should be taken among members.
- It searches the mechanism that is behind the problem and the root cause for the problem is considered.

Work procedure :

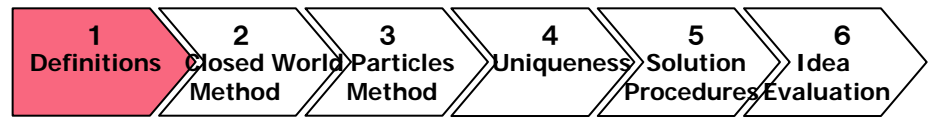
- 1-1. It explains the problem situation.
- 1-2. It illustrate the problem situation.
- 1-3. Set the problem.
- 1-4. Select targeted object.
- 1-5. Suppose the root cause ,then decide the range of the root cause that should be examined.
- 1-6. Make statement of the Core problem.

(omission ..central part..)

★In principle 1-1~1-4 are advanced in order. but If the result of the proceeded process is insufficient, the work is repeated .

★ When the problem is not clear, it is good to do the following “:Analysis of time and a spatial characteristic“
(henceforth abbreviation)

1. Problem Definition



【1-(1) Explanation of problem situation】

About the paper fastener fixed by passing two holes like figure

We applied the USIT approach to the problem of a paper fastener of replacing of papers

Clarification of problem to be solved

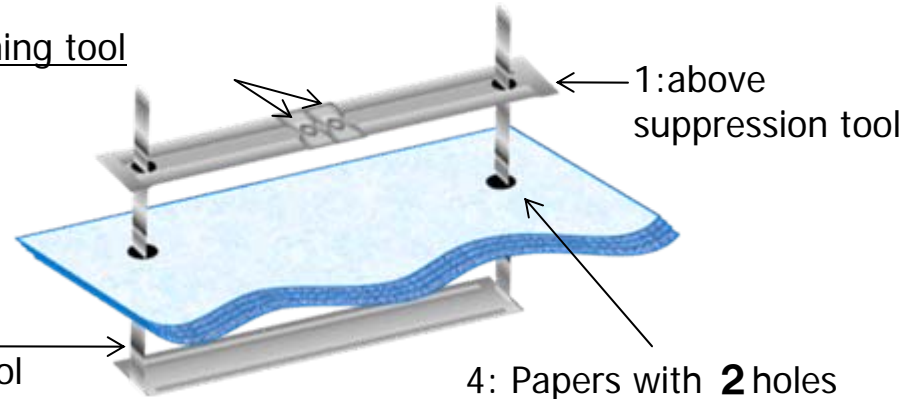
Paper fastener today

is not easy to replace papers

⇒ It takes time and step to replace

3:Fastening tool

2:under
suppression tool

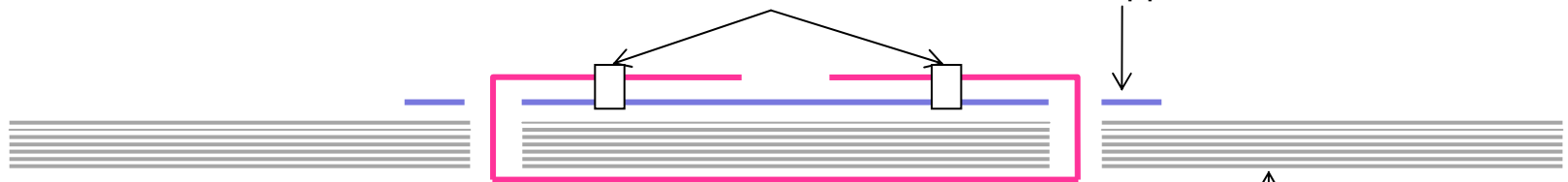


5:hands(fingers)

Figure :from side view (static condition)

3:Fix tool

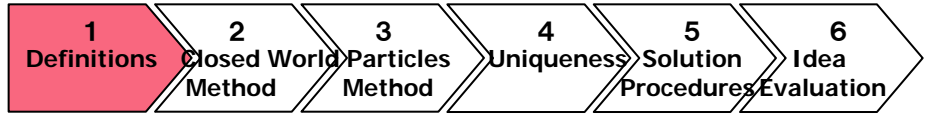
1:above suppression tool



2: Under suppression tool with finger nails

4: Set of Papers(with 2 holes)

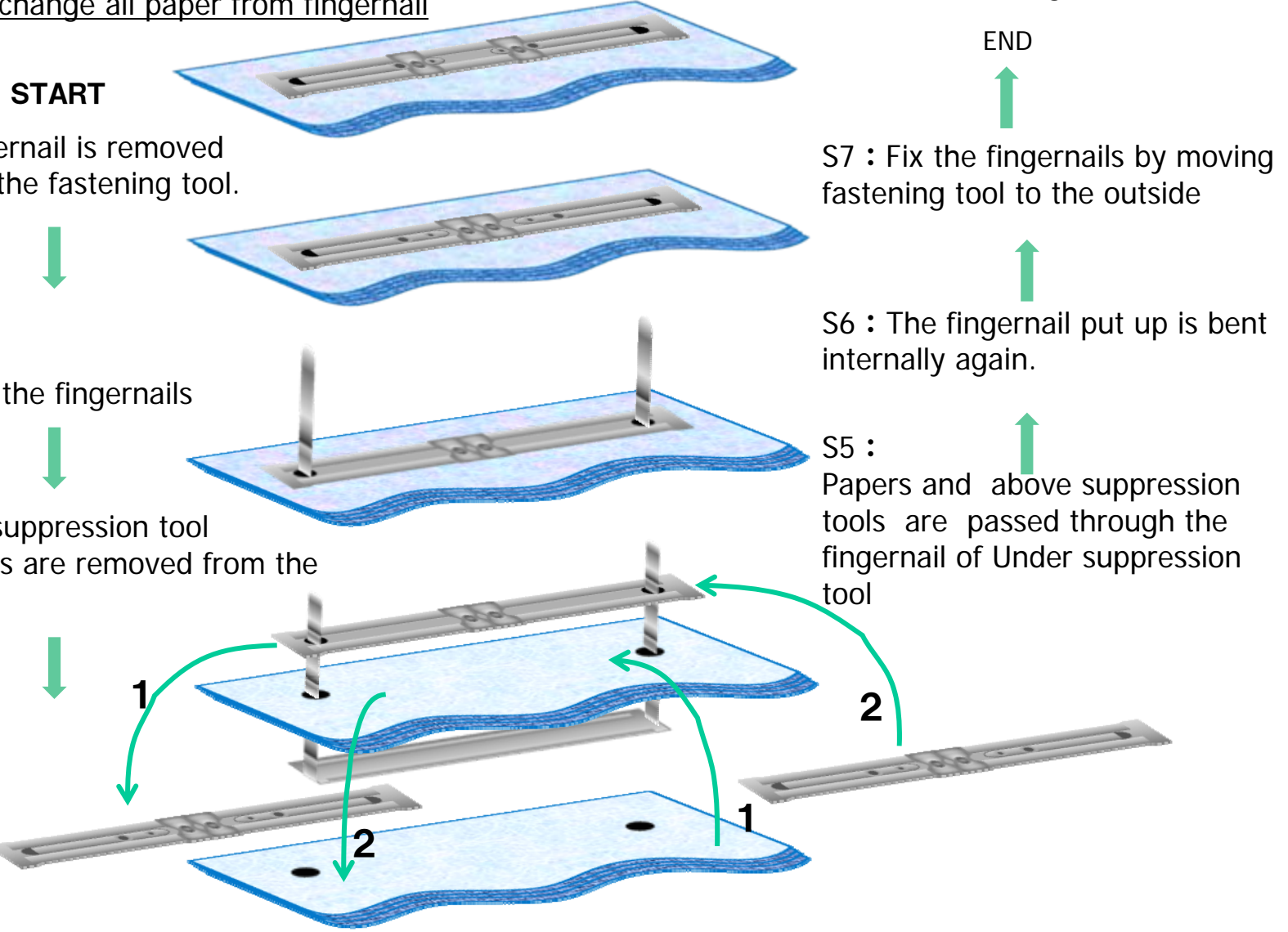
1. Problem Definition



【1—(2) : Figure of problem situation】

Fig1 : Case to change all paper from fingernail

Note: Another case to leave the fingernail exists, too.



START

S1 : The fingernail is removed while moving the fastening tool.

END

S7 : Fix the fingernails by moving fastening tool to the outside

S2 : Stand up the fingernails

S6 : The fingernail put up is bent internally again.

S3 : 1:above suppression tool & all of papers are removed from the fingernail.

S5 : Papers and above suppression tools are passed through the fingernail of Under suppression tool

S4 : An unnecessary pages are pulled out, and New pages are inserted and arranged

1. Problem Definition



【1-(3) Setting of problem 】

Planning the Idea of improvement the paper fastener that can replace the page as easily as possible.

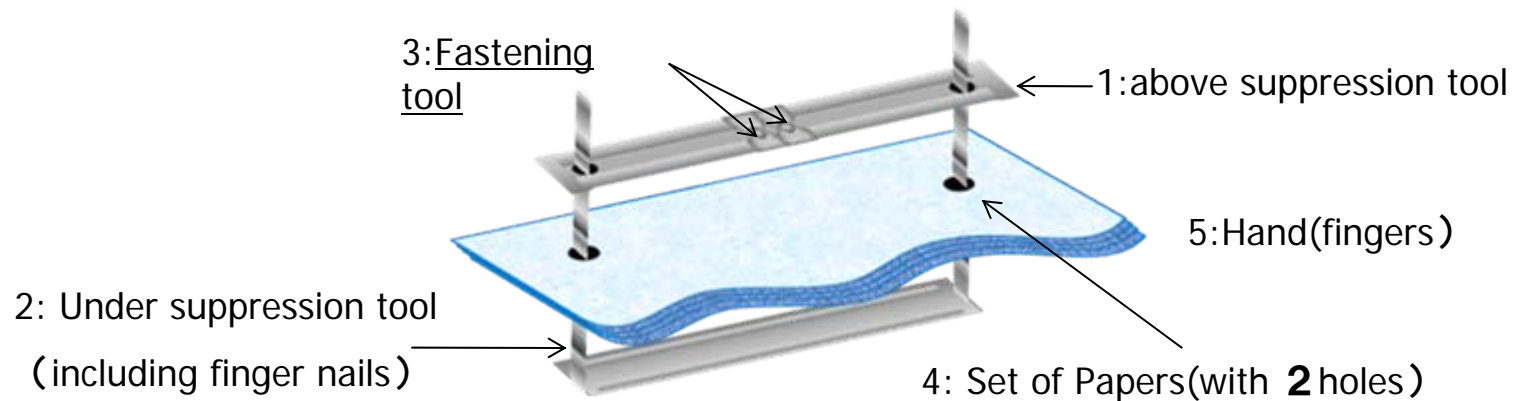
◆ Setting Target & Criterion

1. WANT Condition: Replacement time :as faster as possible.
2. WANT Condition: Replacement steps : as few as possible.

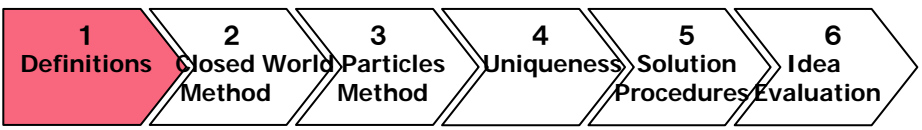
◆ Setting Assumption • Restricted condition

1. Binding by **2**holes (**8cm** Interval)on papers
2. Hole is **5mm** diameter
3. Set of numbers of Papers:keep binding Min 50sheets (Want:100sheets)
4. Thickness of Paper sets : keep binding Min 5mm (Want:**10mm**)

【1-(4)Composed Objects】

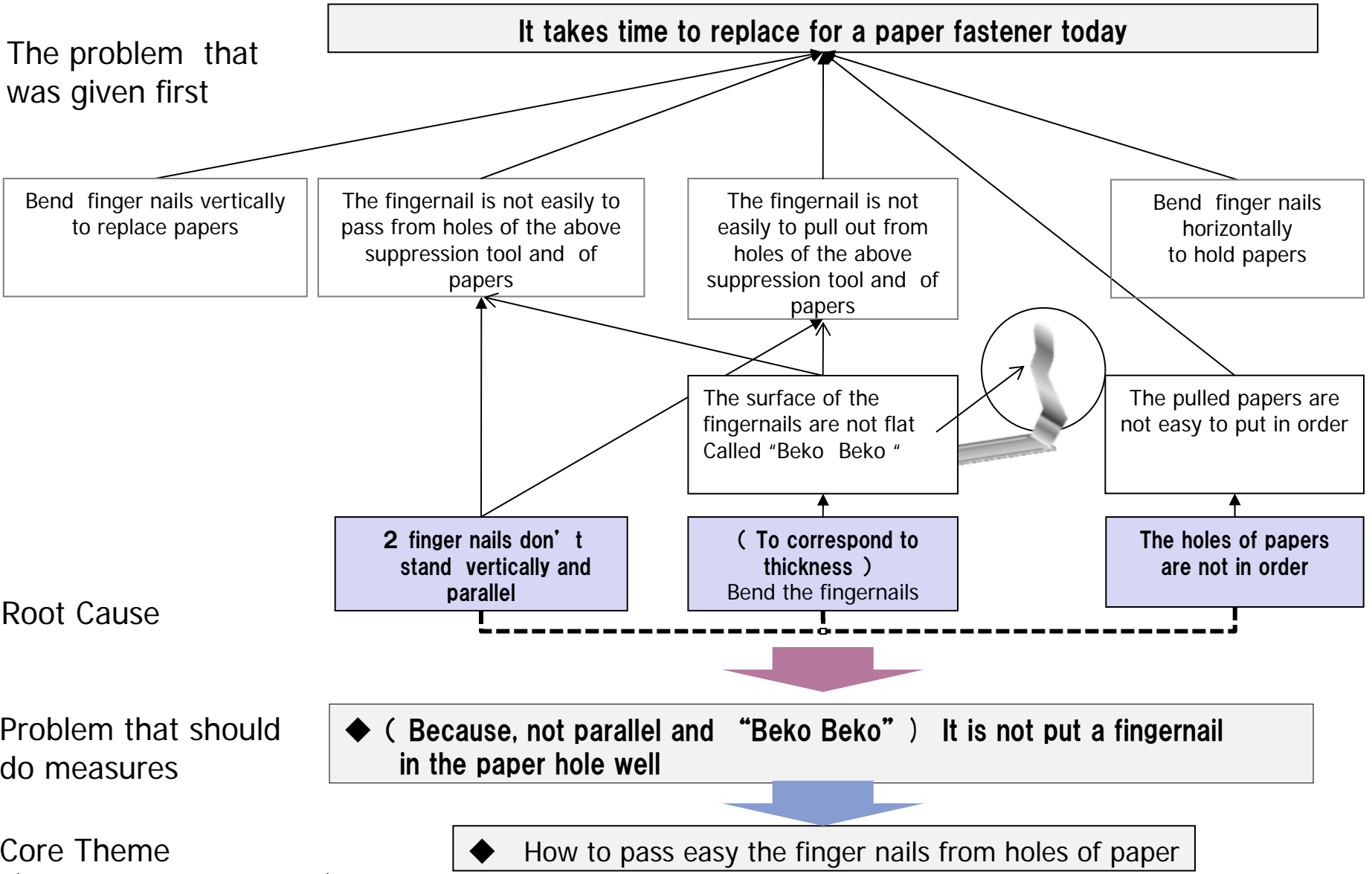


1. Problem Definition



【1-(5) Investigation of Root Cause】

Grasp of the problem situation that should be settled. And the agreement of a range (a domain) that should argue based on the description.



The problem that was given first

Root Cause

Problem that should do measures

Core Theme
(Problem to be solved)

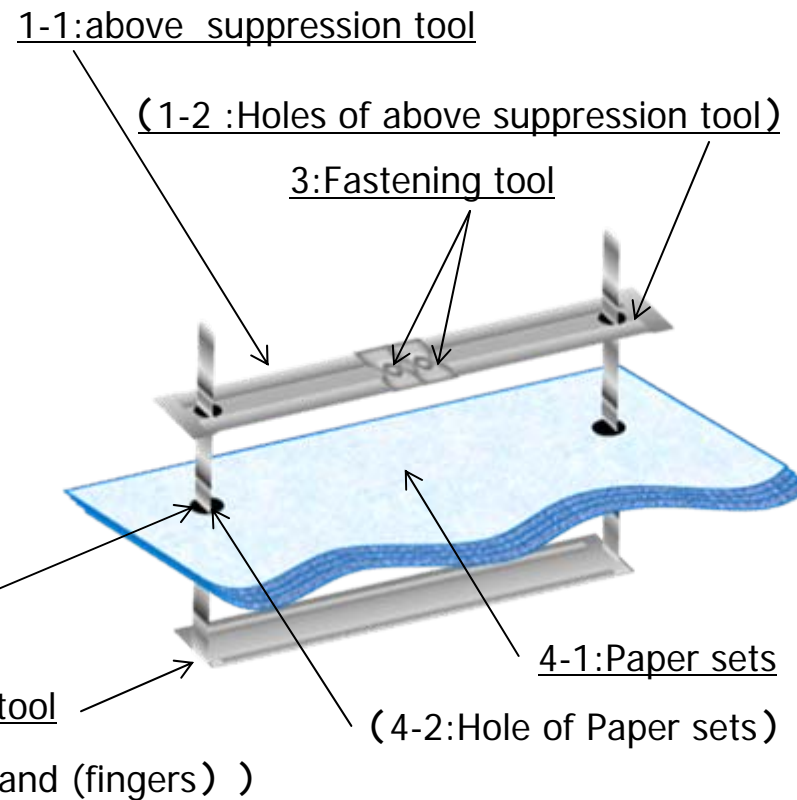
1. Problem Definition



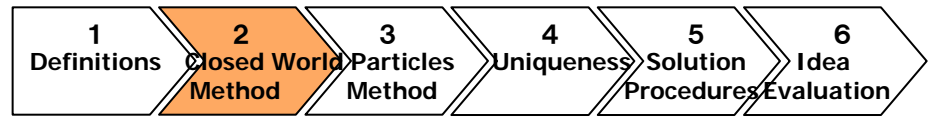
【1-(6) Extract a minimum set of objects】

It is roughly divided by 4 objects. But after analyze the present state shown by the next page, we have decided to subdivide as follows in respect of the function.

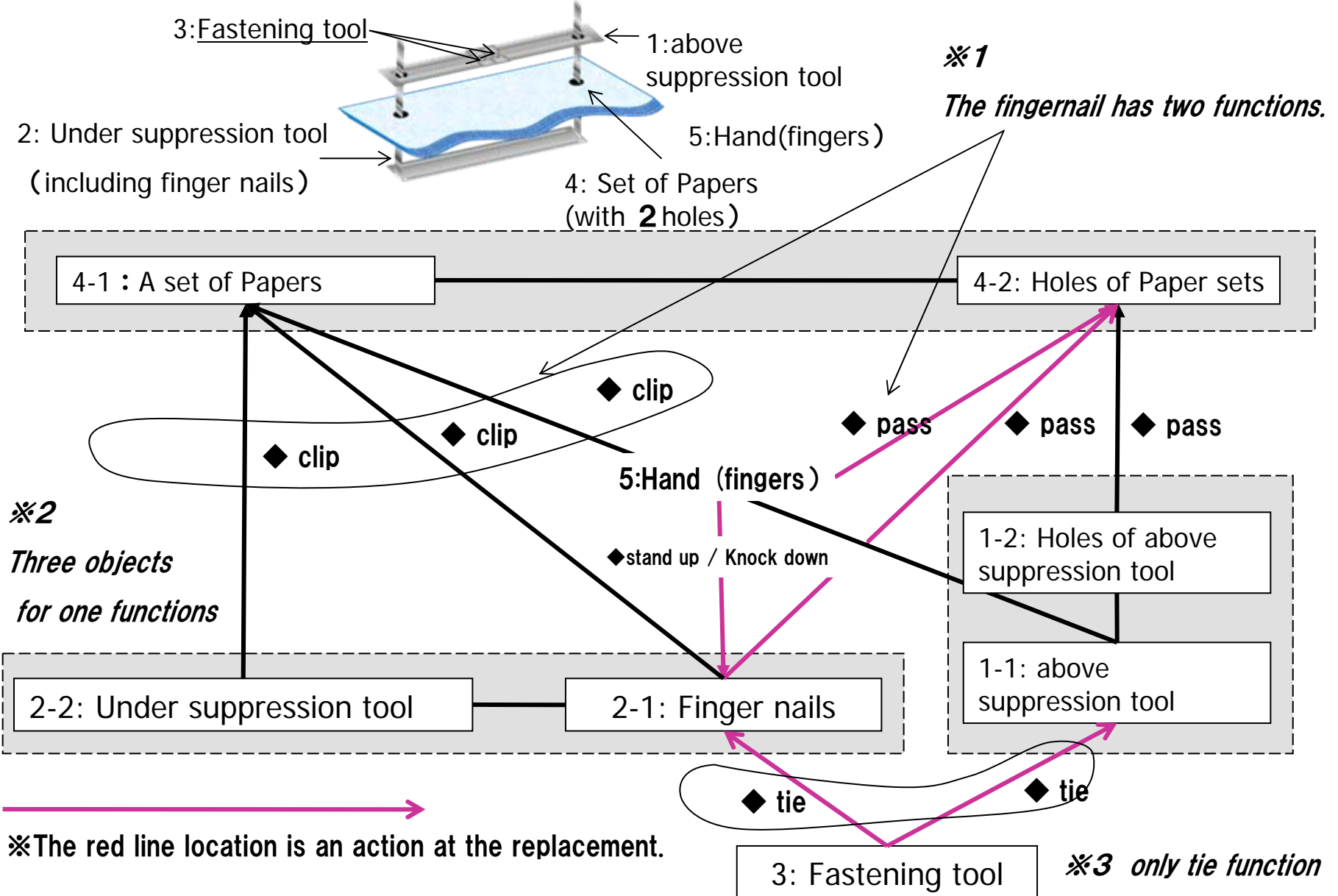
- 1: above suppression tool •••>
 - 1-1: above suppression tool
 - (1-2: Holes of above suppression tool)
- 2: 2-2:Under suppression tool •••>
 - 2-1: Finger nails of Under suppression tool
 - 2-2: Under suppression tool
- 3: Fastening tool
- 4: Paper sets •••>
 - 4-1: Paper sets
 - (4-2: Holes of Paper sets)
- (5:Hand (fingers))



2. Closed World Method



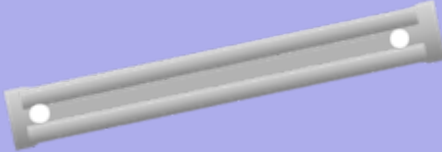

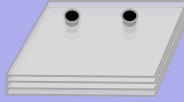
【2-(1) Closed World Diagram】



2. Closed World Method



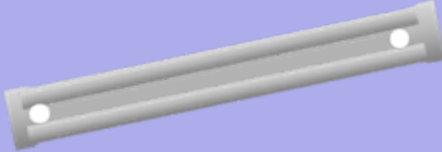

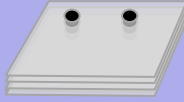
【2- (2) List up the Attributes of Objects】 【2- (3) QC-Matrix】

Function of Replacing					
	Easy to Replace (+)	Difficult to replace (-)	2-1: Finger nails	2-2: Under suppression tool	4-1: Paper sets
Length	◎ (-)		◎ (-)		
Weight	◎ (-)			◎ (+)	
Thickness					◎ (-)
Width and area	◎ (-)	◎ (+)	◎ (-)	◎ (+)	
Shape		◎	◎ Root ◎ Section ◎ Levelness+ (Degree of "Beko Beko")	- - - Levelness	
Hardness (rigidity)	◎ (-)		◎ (+/-)	◎ (-)	◎ (+)
Elasticity			◎ (+)	◎ (+)	

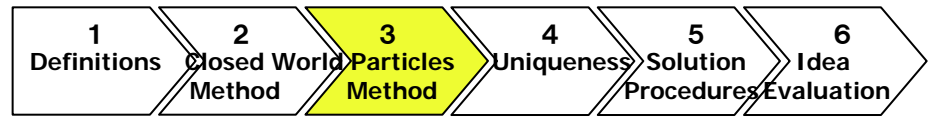
2. Closed World Method



【2- (2) List up the Attributes of Objects 】 【2- (3) OA-Matrix 】

Function that clips it It firmly clips it. (+) It is easy to come off (-)					
	1-1: above suppression tool	1-2: Holes of above suppression tool	2-1: Finger nails	2-2: Under suppression tool	4-1: Paper sets
Length	◎ (+)		◎ (+)		
Weight	◎ (+)			◎ (+)	
Thickness					◎ (-)
Width and area	◎ (+)	◎ (-)	◎ (+)	◎ (+)	
Shape		◎	◎ Root ◎ Section ◎ Levelness+ (Degree of "Beko Beko")		
Hardness (rigidity)	◎ (+)		◎ (+/-)	◎ (+)	◎ (+)
Elasticity					

3. Particles Method

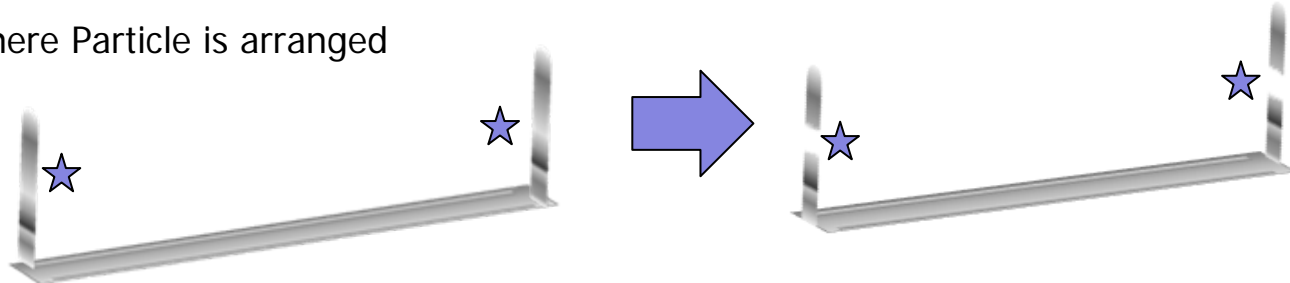


【3- (1) sketch of problem situation and solution Idea 】

【3- (2) arrangement and application of Particle】

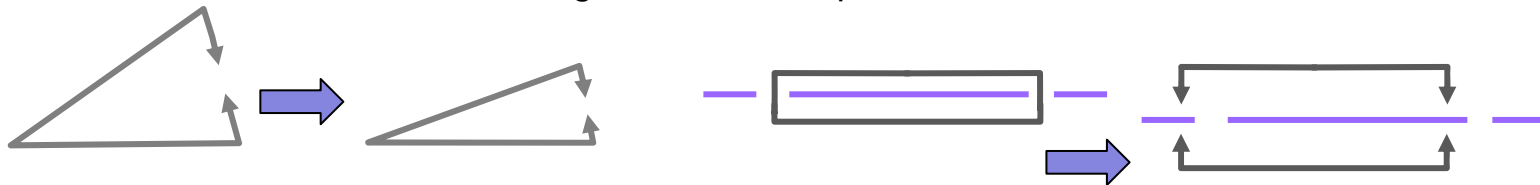
1 : The current state: Remove the suppression tool and papers from the fingernails

★ Part where Particle is arranged



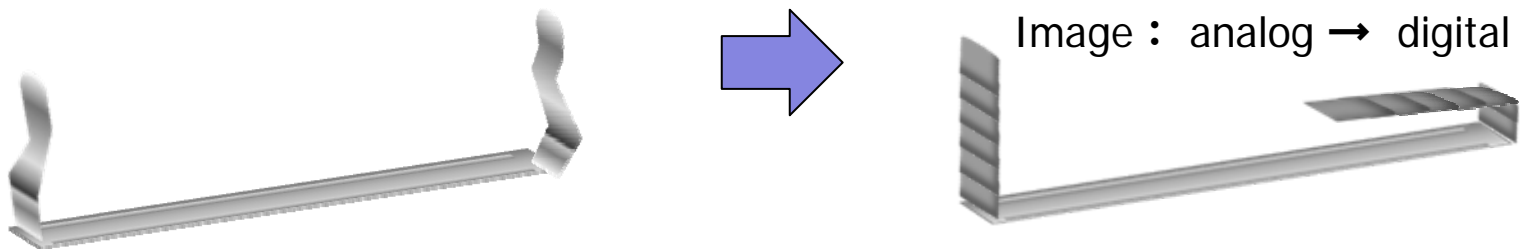
The ideal state: PARTICLES divides the fingernail at the replacement

Image



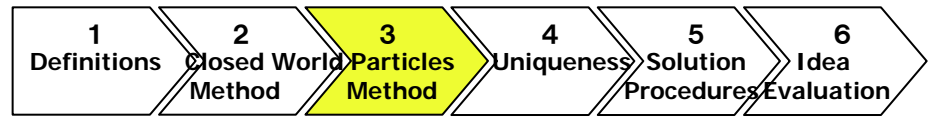
2 : It becomes [bekobeko] on the way of the fingernail and paper is caught.

The current state: It becomes difficult to pull out, and to insert because of the fingernail which become [bekobeko] after using many times like the picture below



The ideal condition: The structure and the character that the fingernail doesn't become [bekobeko]

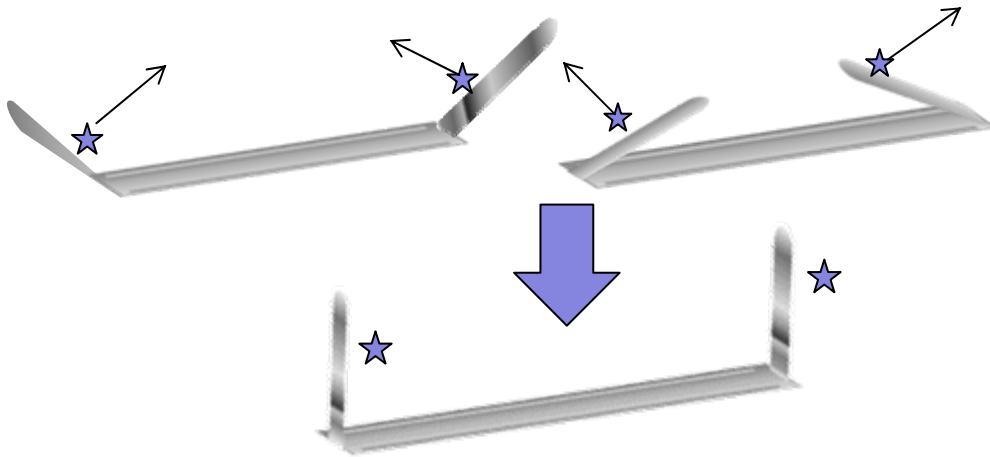
3. Particles Method



【3- (1) sketch of problem situation and solution Idea 】

【3- (2) arrangement and application of Particle】

3: It is easy to pass neither the hole that passes paper nor the hole of the above suppression tool if the interval of a right and left fingernail is not regular

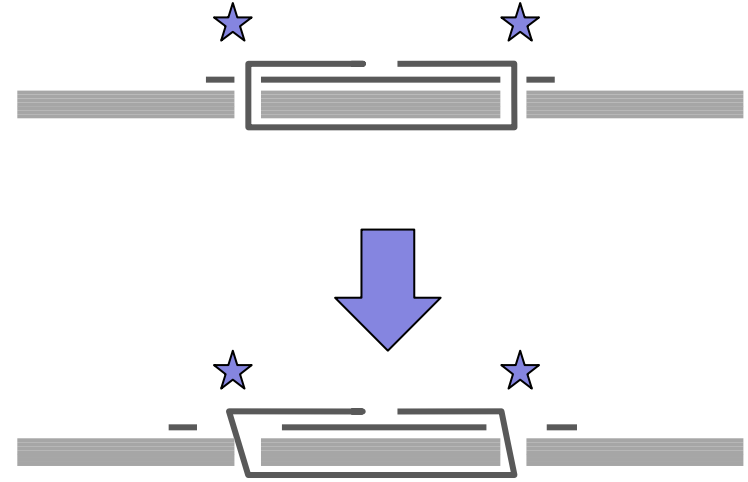


◆ The fingernail is good to be right-angled or parallel at the replacement (Especially, when inserting)

Image : Squarely curved mechanism

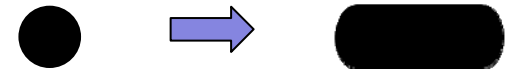


Figure seen on

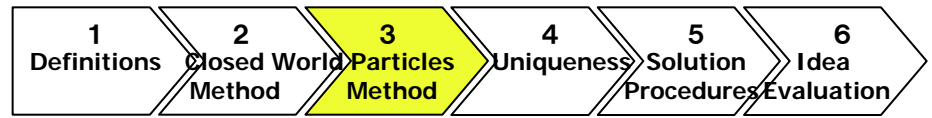


◆ Even if the interval of the fingernail shifts somewhat, it makes it to a safe structure.

Image : The redundancy hole of oblong shape



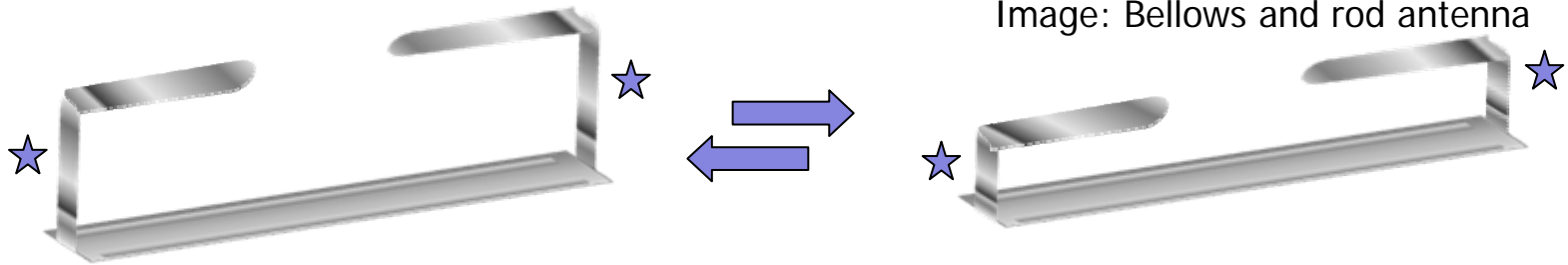
3. Particles Method



【3- (1) sketch of problem situation and solution Idea 】

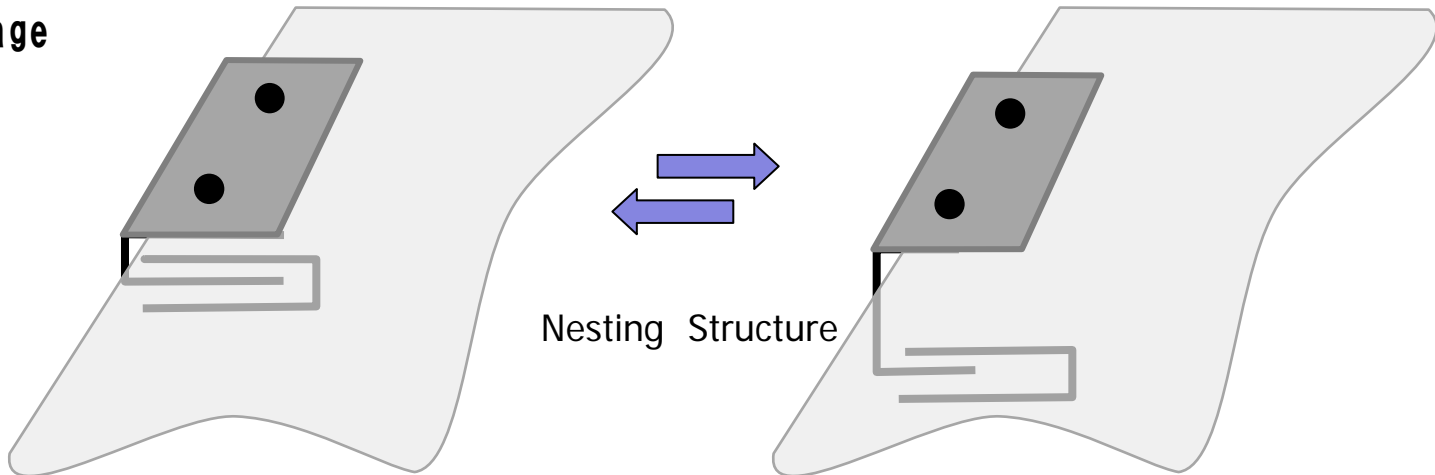
【3- (2) arrangement and application of Particle】

4 : The length of the fingernail is setting at a long size in consideration of the thickness of setting papers.



The ideal: The length of the fingernail is changed in proportion to the thickness of paper. The fingernail shortens when pulling out and inserting

Image



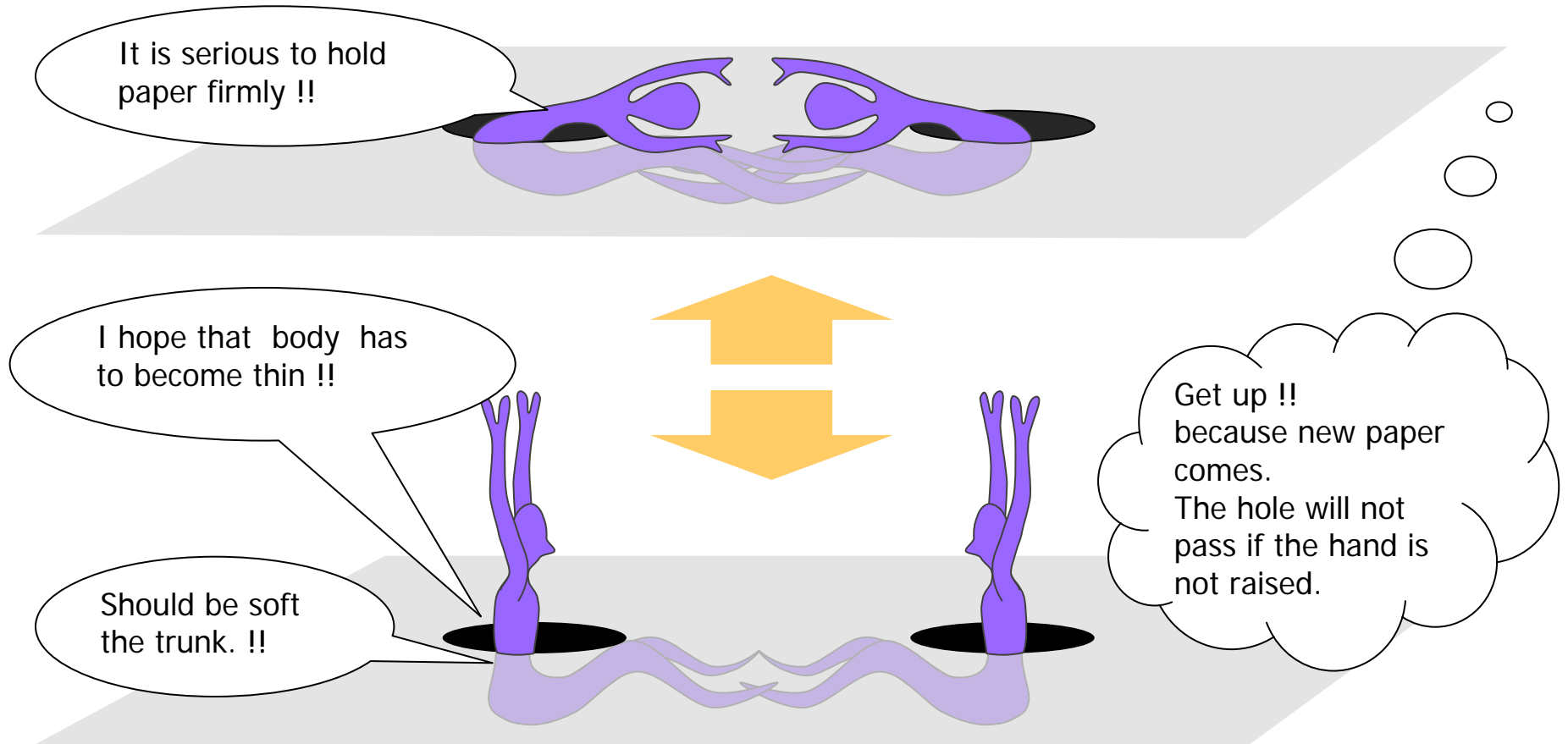
3. Particles Method



【3-(3) . Smart Personified object : Morph cartoon by the object itself is personified】

Clipping function

method 1: It is current state of arrangement fingernail is in horizontal direction



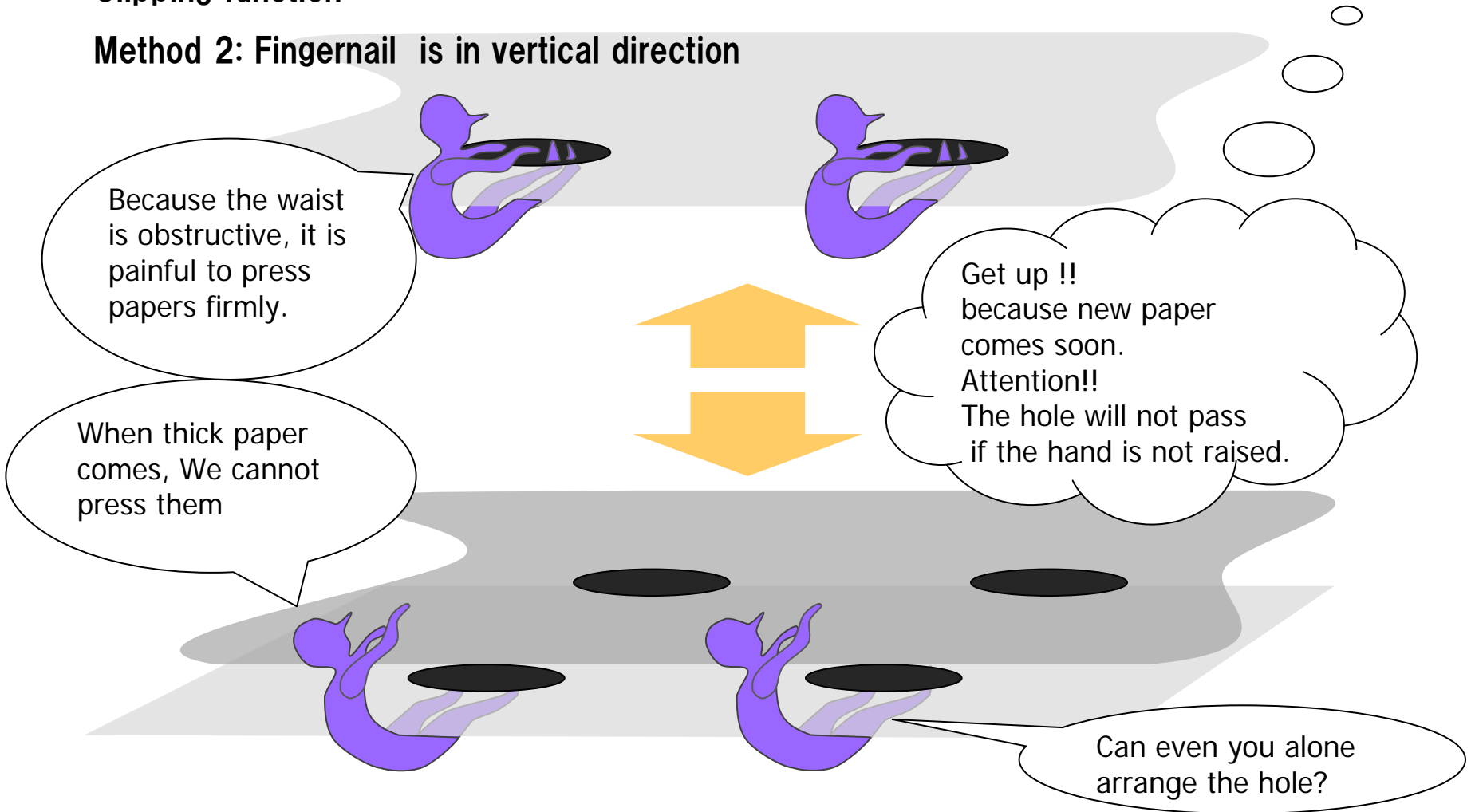
3. Particles Method



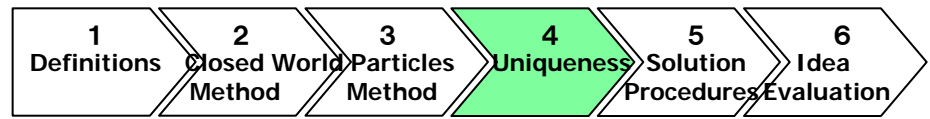
【3-(3) . Smart Personified object : Morph cartoon by the object itself is personified】

Clipping function

Method 2: Fingernail is in vertical direction

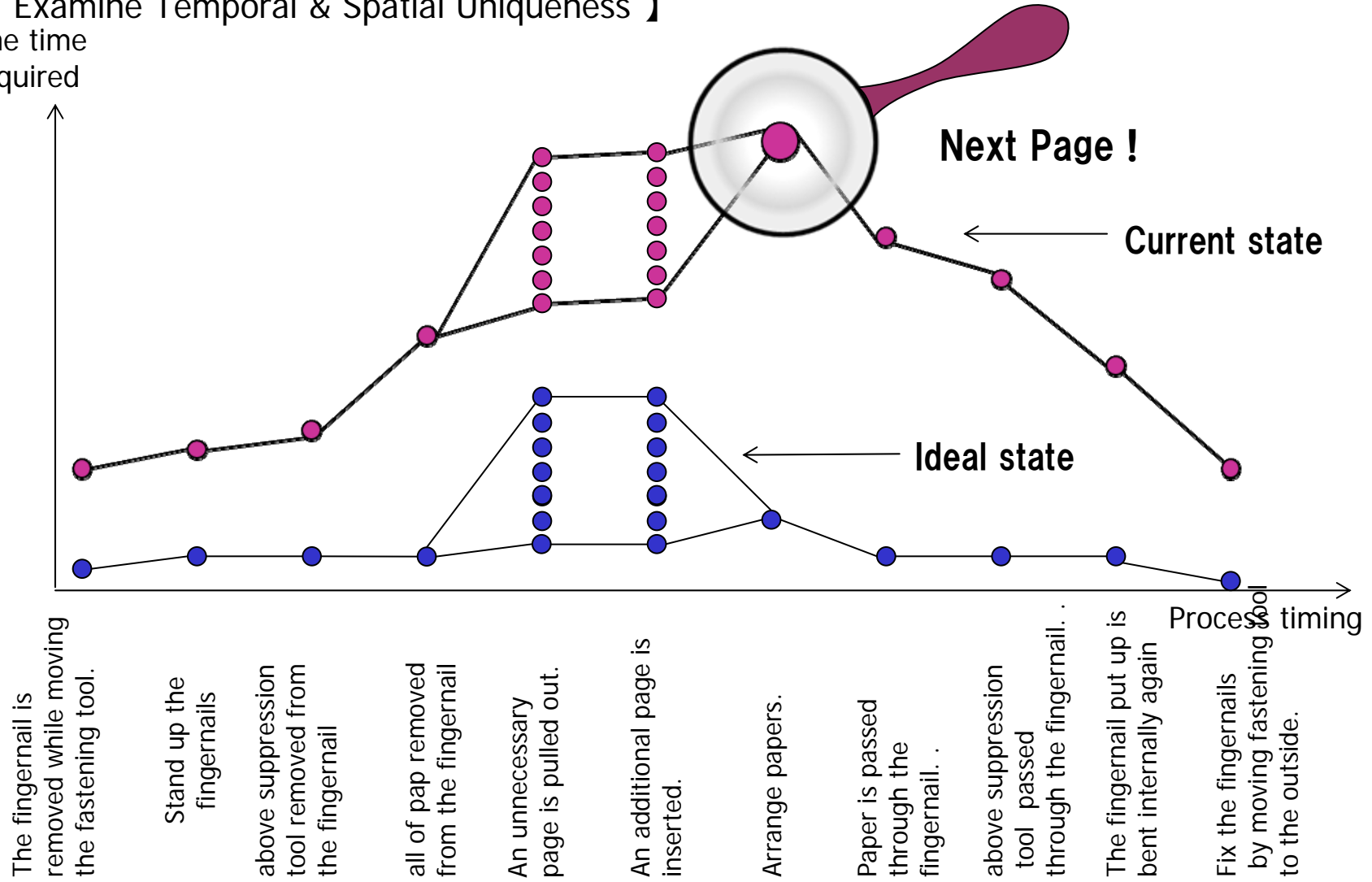


4. Uniqueness



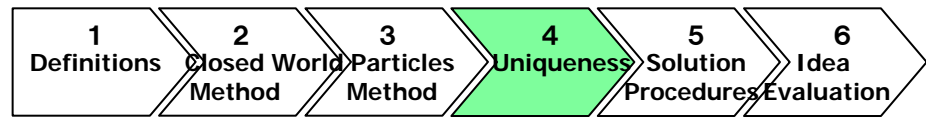
【4-1 : Examine Temporal & Spatial Uniqueness】

The time required



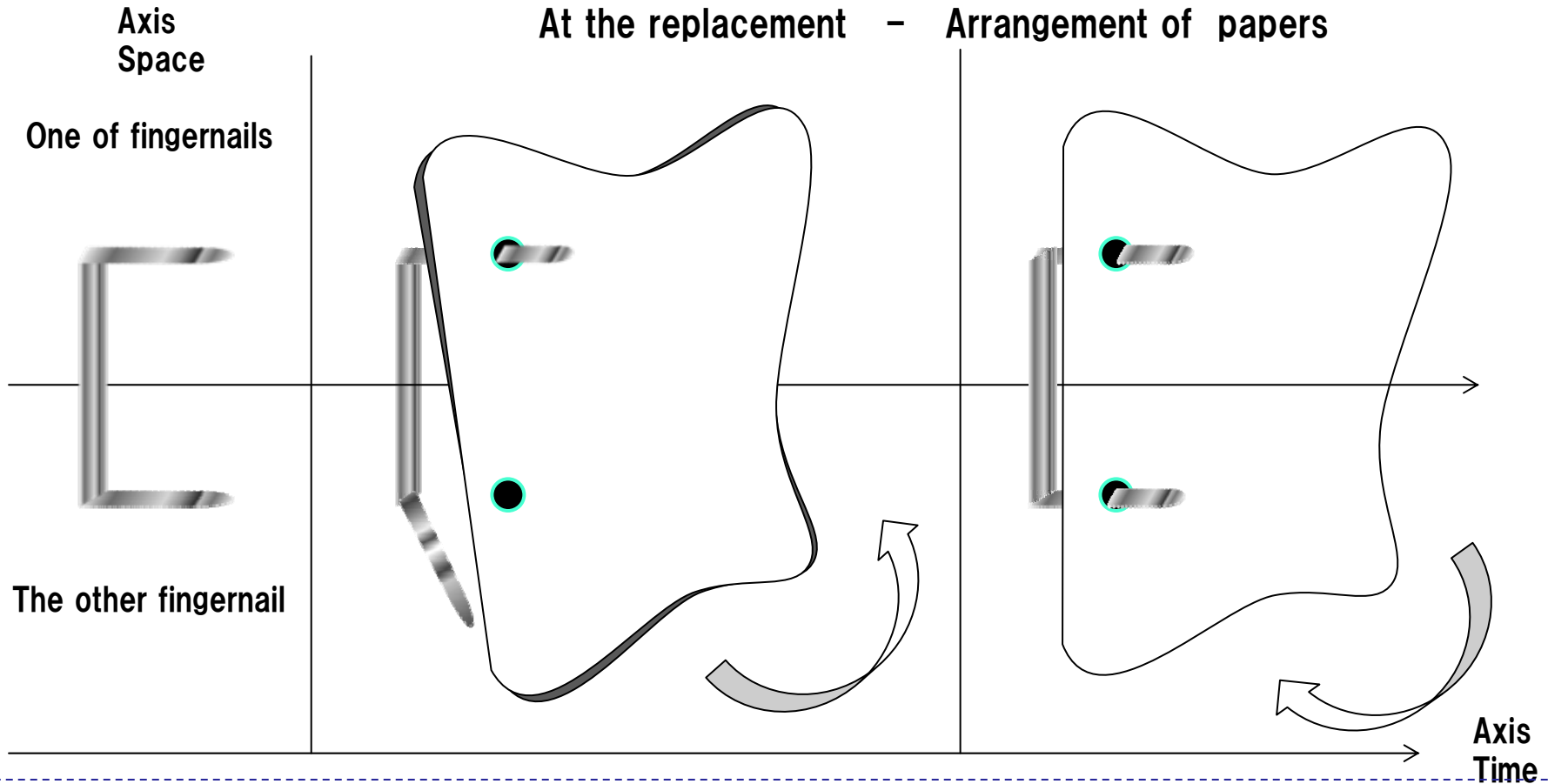
- The most time-consuming troublesome operation is a arrangement of paper.
- Cannot omit the operation of the fastening tools ?

4. Uniqueness



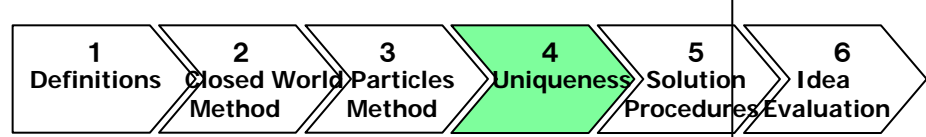
【4-2 : Examine Temporal & Spatial Uniqueness】 Scene that papers is arranged by using fingernail

At the replacement - Arrangement of papers

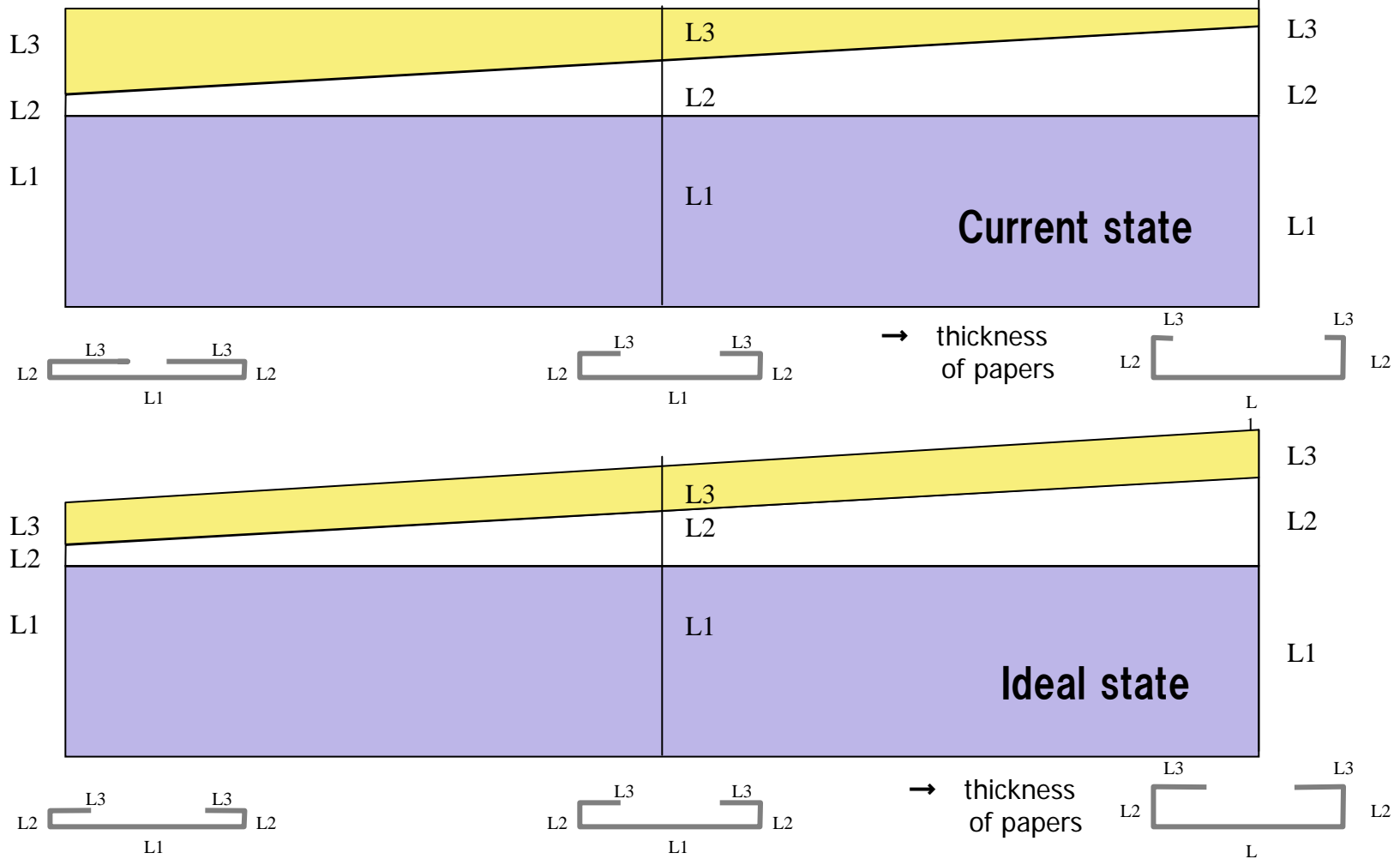


- It passes it on the tip of one of fingernails at the arrangement of papers
At this time, it is understood that extra operation enters by putting the fingernail to sleep so that the other fingernail may become obstructive. So try to rotate the paper bunch ,or bending it up.
- The idea occurs as follows.
Entrusts the function to arrange to one fingernail
The other tool that another fingernail don't give harm

4. Uniqueness



【4-2 : Examine Temporal & Spatial Uniqueness】



- The thickness of papers increases. →L2 increases →L3 shortens
→ becomes easy for the fingernail to come off
- It can be said that L2 is expanded in proportion to the thickness of papers and L3's length are keep constant are the ideals.

5. Solution Procedures



【5-1 Solution Generation Methods - Primary Step】

USIT Operator Brief version Ver.2.31

© Yuji Mihara Creative Technology Institute Co. Ltd.)

1 Object Pluralization Method

Elimination • Unification

- a. Eliminate
- b. Unify

Increase / Introduction

- c. Multiply into 2,3,··,inf.
- d. Introduce or Modify
- e. Introduce from the Environment

Division • Distribution

- f. Divide into 1/2,1/3,··,1/inf.

Generalize • Substitute • Substitute

- g. Exchange the generalized Object
- h. From Solid to Powder/Liquid/Gas

2 Attribute Dimensionality Method

Elimination • Unification

- a. Deactivate a Harmful
- b. Suppress a Harmful

Increase / Introduction

- c. Enhance a Useful
- d. Pay attention a Useful
- e. Introduce a Spatial Attribute
- f. Introduce a Temporal Attribute
- g. Attributes at the Micro Level
- h. Properties of the System as a Whole

Division • Distribution

- i. Vary in Space
- j. Vary in Time

Generalize • Substitute • Substitute

- k. Change the Phase or the Inner-Structure

3 Function Distribution Method

Elimination • Unification

- a. Unify multiple Function

Increase / Introduction

- b. Introduce a new Function
- c. Detection/measurement Function
- d. Enhance adapting /coordination/control

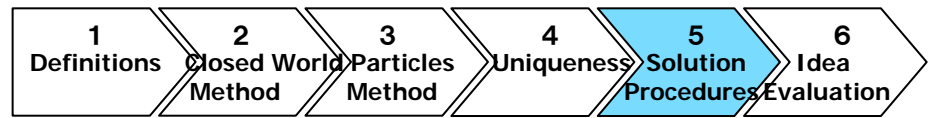
Division • Distribution

- e. Divide the compound Functions and assign them separately
- f. Vary the Function in Space
- g. Vary the Function in Time

Generalize • Substitute • Substitute

- h. Exchange the generalized Function
- i. Reassign to a different Object
- j. With a different physical principle

5. Solution Procedures



【5-1 Solution Generation Methods - Primary Step】

1) Idea generation from Object

Elimination • Unification

- a. Eliminate
- b. Unify

Closed World Diagram

1a: ◆ The function of the fastening tool is achieved by the above suppression tool and the fingernail.
 ◆ The above tool can be removed, and the points of the tab be united mutually

O-A Matrix Chart

Particles Method

1c:

◆ The fingernail is increased and nested.

1d:

◆ Rubber is put on the way of the fingernail.
 ◆ The spring is put on the way of the fingernail.

1c:

◆ The fingernail is increased and nested.

1d:

◆ Rubber is put on the way of the fingernail.
 ◆ The spring is put on the way of the fingernail.

Division • Distribution

- f. Divide into 1/2, 1/3, ..., 1/inf.

1f:

◆ The fingernail is divided, and the pulling out inserting of paper is done.

Generalize • Substitute • Substitute

- g. Exchange the generalized Object
- h. From Solid to Powder/Liquid/Gas

5. Solution Procedures



【5-1 Solution Generation Methods - Primary Step】

2) Idea generation from Attribute

Elimination • Unification

- a. Deactivate a Harmful
- b. Suppress a Harmful

Increase / Introduction

- c. Enhance a Useful
- d. Pay attention a Useful
- e. Introduce a Spatial Attribute
- f. Introduce a Temporal Attribute
- g. Attributes at the Micro Level
- h. Properties of the System as a Whole

Division • Distribution

- i. Vary in Space
- j. Vary in Time

Generalize • Substitute • Substitute

- k. Change the Phase or the Inner-Structure

Closed World Diagram	O-A Matrix Chart	Particles Method
<p>2a:</p> <ul style="list-style-type: none"> ◆ The fingernail doesn't pass the hole of paper. ◆ Adjusting paper by one fingernails. 	<p>2a:</p> <ul style="list-style-type: none"> ◆ Reduces diameter of one of fingernails <p>2b: ◆ Only a right-angled direction bends.</p>	
	<p>2c:</p> <ul style="list-style-type: none"> ◆ The area of the above suppression is wide. ◆ The hole of the above suppression to the oblong <p>2d: ◆ The point of the fingernail is thin.</p> <ul style="list-style-type: none"> ◆ The replacement part of the fingernail is hard. 	<p>2c:</p> <ul style="list-style-type: none"> ◆ The length of the fingernail changes in accordance with the thickness of paper. <p>2d</p> <ul style="list-style-type: none"> ◆ The fingernail is nested. ◆ The fingernails are attached with magnet
	<p>2f:</p> <ul style="list-style-type: none"> ◆ The top shape of the fingernail is like a cone. ◆ The place that the fingernail bends is soft. <p>2g:</p> <ul style="list-style-type: none"> ◆ The section of the is round at the replacement, and it is flat 	<p>2f</p> <ul style="list-style-type: none"> ◆ Rubber is put on the way of the fingernail. ◆ The spring is put on the way of the fingernail.

5. Solution Procedures



【5-1 Solution Generation Methods - Primary Step】

3) Idea generation from Function

Elimination • Uunification

a. Unify multiple Function

Increase / Introduction

- b. Introduce a new Function
- c. Detection/measurement Function
- d. Enhance adapting /coordination/control

Division • Distribution

- e. Divide the compound Functions and assign them separately
- f. Vary the Function in Space
- g. Vary the Function in Time

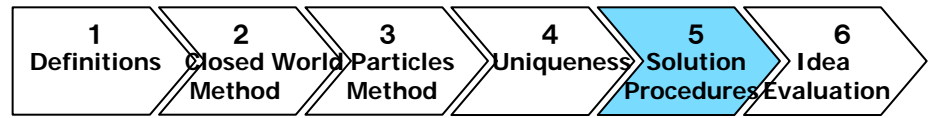
Generalize • Substitute • Substitute

- h. Exchange the generalized Function
- i. Reassign to a different Object
- j. With a different physical principle

Closed World Diagram	O-A Matrix Chart	Particles Method
		3b: ◆ It opens on the way of the fingernail ◆ It arrange by under suppression ◆ The fingernail is nested changes in proportion to the thickness of paper
3e ◆ The function to suppress is provided for the fingernail by omitting above press tool		
3i ◆ The function of the fastening tool is achieved by the above suppression tool ◆ The function to suppress is provided besides the fingernail		3j: ◆ It is made easily to replace by breaking the fingernail like the joint ◆ Paper is pressed with the magnet ◆ The fingernails like tooth brush become able to pull out and insert papers

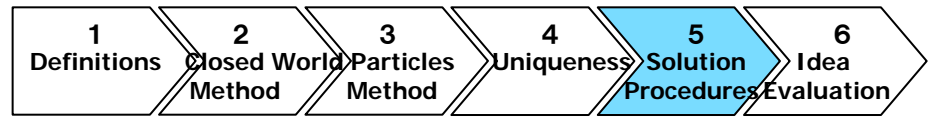
5. Solution Procedures

【5-1 Solution Generation Methods】



		A : easy to pass through fingernails	B : easy to arrange	C: follows to thickness	D: Press firmly
Idea generation from Object	<ul style="list-style-type: none"> ◆ The function of the fastening tool is achieved by the above suppression tool and the fingernail. ◆ The above tool can be removed, and the points of the tab be united mutually ◆ The fingernail is increased and nested. ◆ The spring is put on the way of the fingernailする 	● ● ●		● ●	●
Idea generation from Attribute	<ul style="list-style-type: none"> ◆ The area of the above suppression is wide ◆ The hole of the above suppression to the oblong ◆ The point of the fingernail is thin. ◆ The replacement part of the fingernail is hard. ◆ The length of the fingernail changes in accordance with the thickness of paper. ◆ The top shape of the fingernail is like a cone. ◆ The place that the fingernail bends is soft. ◆ The section of the is round at the replacement, and it is flat after the replacement. ◆ Rubber is put on the way of the fingernail. ◆ Reduces diameter of one of fingernails ◆ Adjusting paper by one fingernails. ◆ The fingernail doesn't pass the hole of paper. 	● ● ● ● ● ● ● ● ●	● ● ● ●	● ● ●	●
Idea generation from Function	<ul style="list-style-type: none"> ◆ It opens on the way of the fingernail ◆ It arrange by upper fingernail & under suppression ◆ The fingernail is nested changes according to the thickness of paper ◆ The function to suppress is provided for the fingernail by omitting above press tool ◆ The function of the fastening tool is achieved by the above suppression tool ◆ The function to suppress is provided besides the fingernail ◆ It is made easily to replace by breaking the fingernail like the joint ◆ Paper is pressed with the magnet ◆ The fingernails like tooth brush become able to pull out and insert papers 	● ● ● ● ● ●	●	● ●	● ●

5. Solution Procedures



Pass easy the finger nails from holes of papers

A : easy to pull out and to insert **B** : easy to arrange **C** : possible to follow to thickness. **D** : firmly fix and clip

A 1

- divides during the fingernail

B 1

- Fingernail of conical geometry

C 1

- Bellows
- Spring

D 1

- Magnet/ Joint by ruggedness
- Spring

A 2

- Switch (squarely bended)

B 2

- arrange by upper fingernail & under suppress tool

C 2

- Nested suppression tool

D 2

- Horizontal fingernail type

A 3

- It bends in the decided place

B 3

- arranges by 1 fingernails.
- One of fingernails are thin

C 3

- Nested fingernail

D 3

- Vertical fingernail type

A 4

Oval hole

B 4

- It holds down in the place of the hole.

C 4

- Let it be

D 4

- expand the area of the suppression tool

5. Solution Procedures



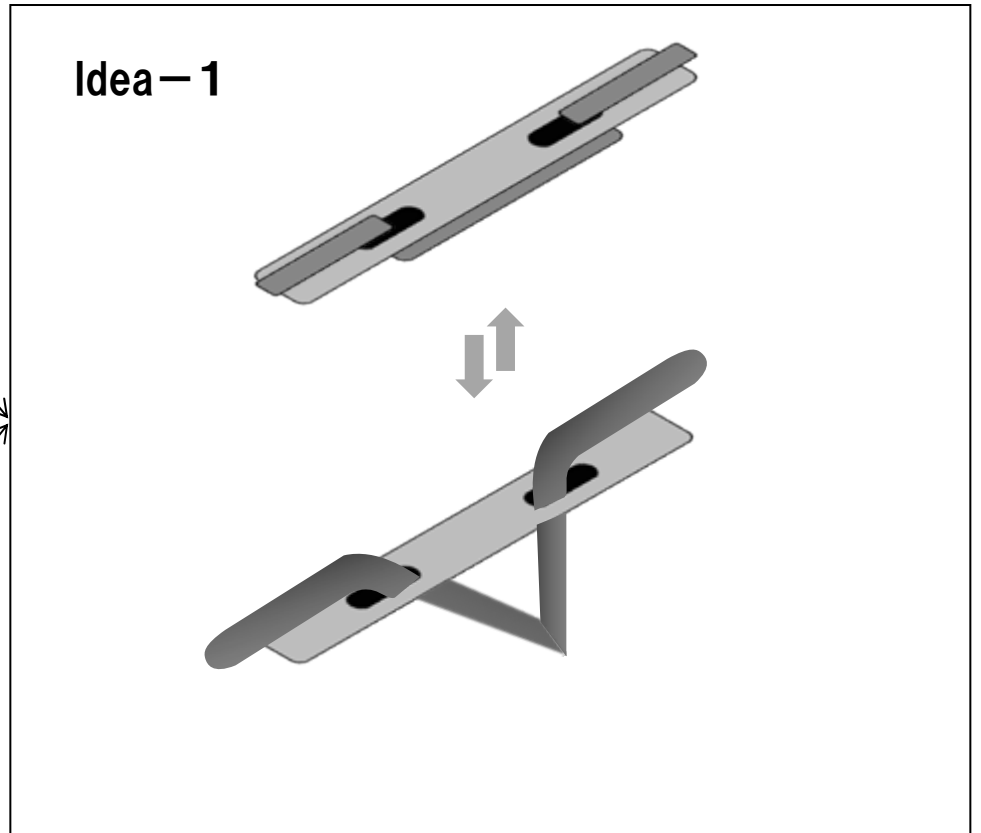
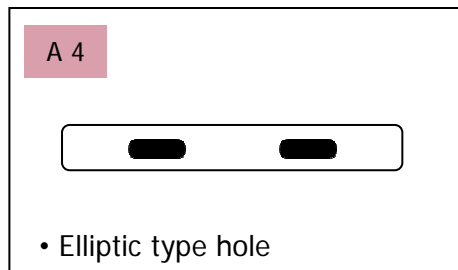
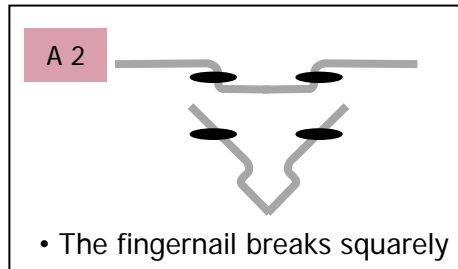
【5-2 Solution Generation Methods】

【 Secondary Step 】

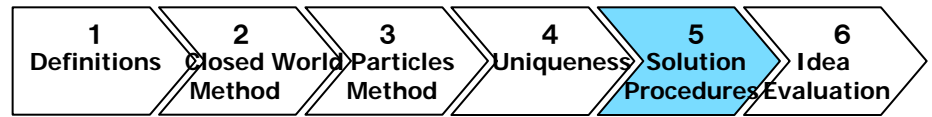
Generation by Solution Combination

- a. Combine the plural Solutions
 - i) Combine functionally
 - ii) Combine spatially
 - iii) Combine temporally
 - iv) Combine structurally
 - v) Combine principle level
- b. Combine at the Super-System level
- c. Removal of the Fault in the Solution

a- iv) Combine structurally



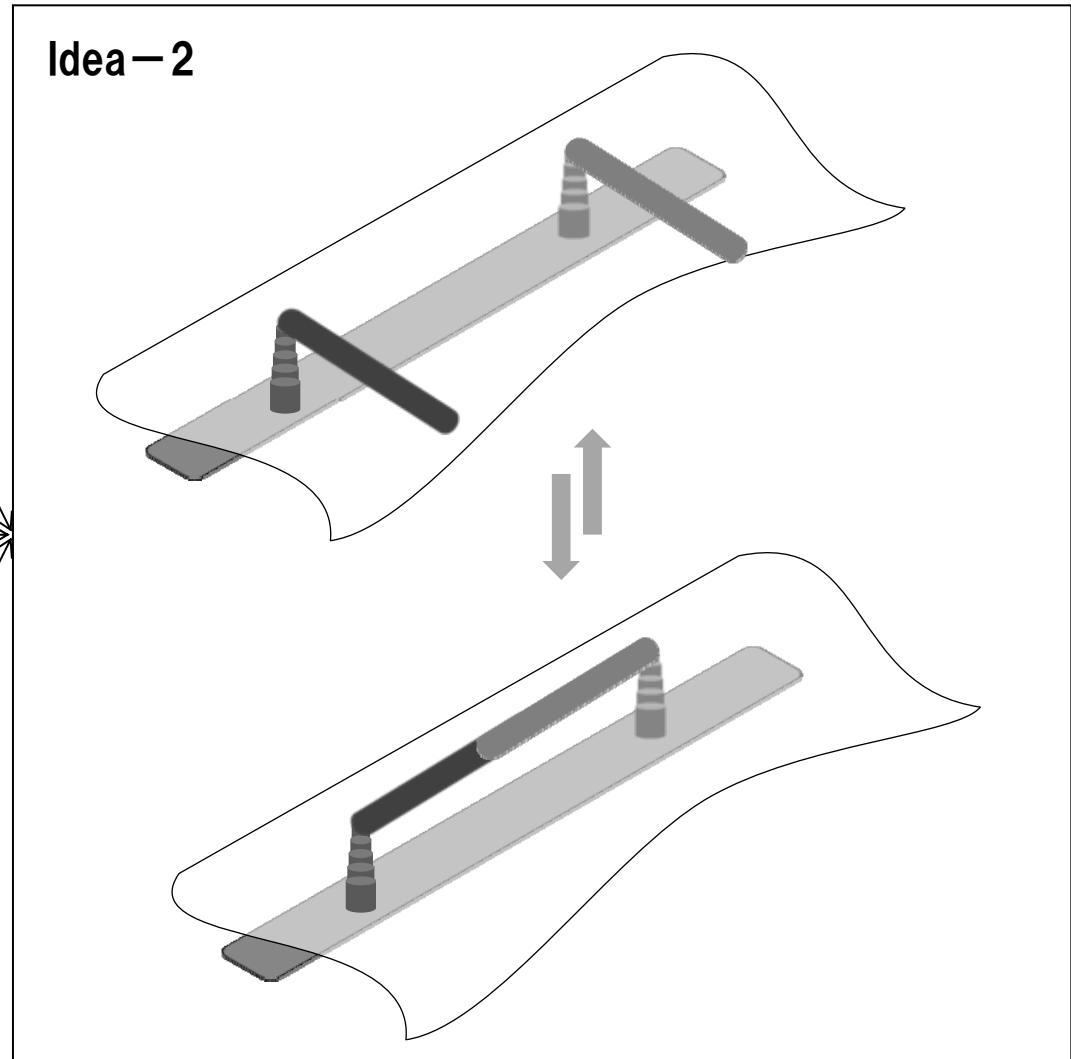
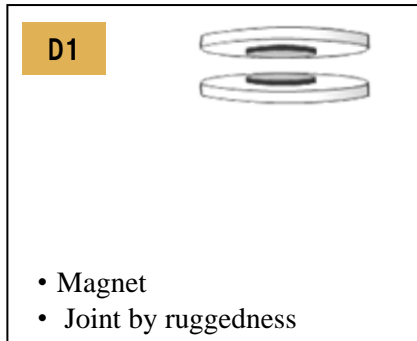
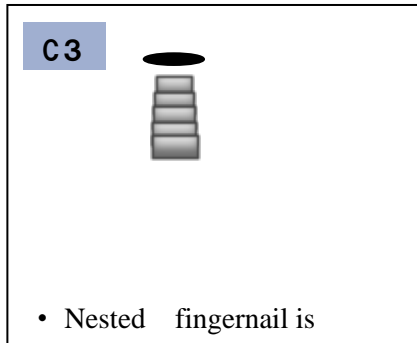
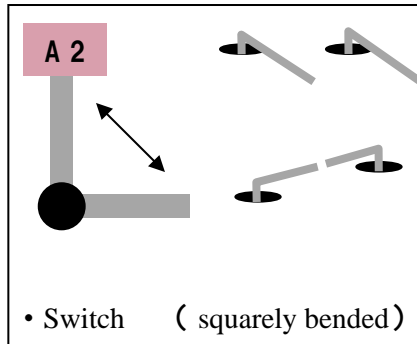
5. Solution Procedures



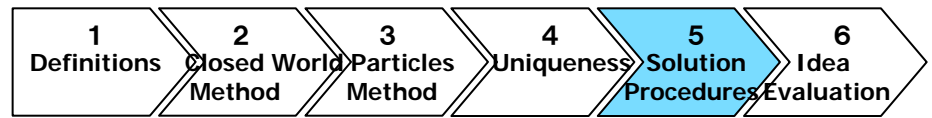
【5-2 Solution Generation Methods】

【 Secondary Step 】 Generation by Solution Combination

- a- i) Combine functionally
- a- iv) Combine structurally




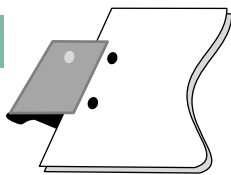
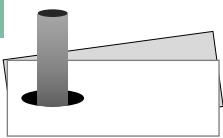


5. Solution Procedures

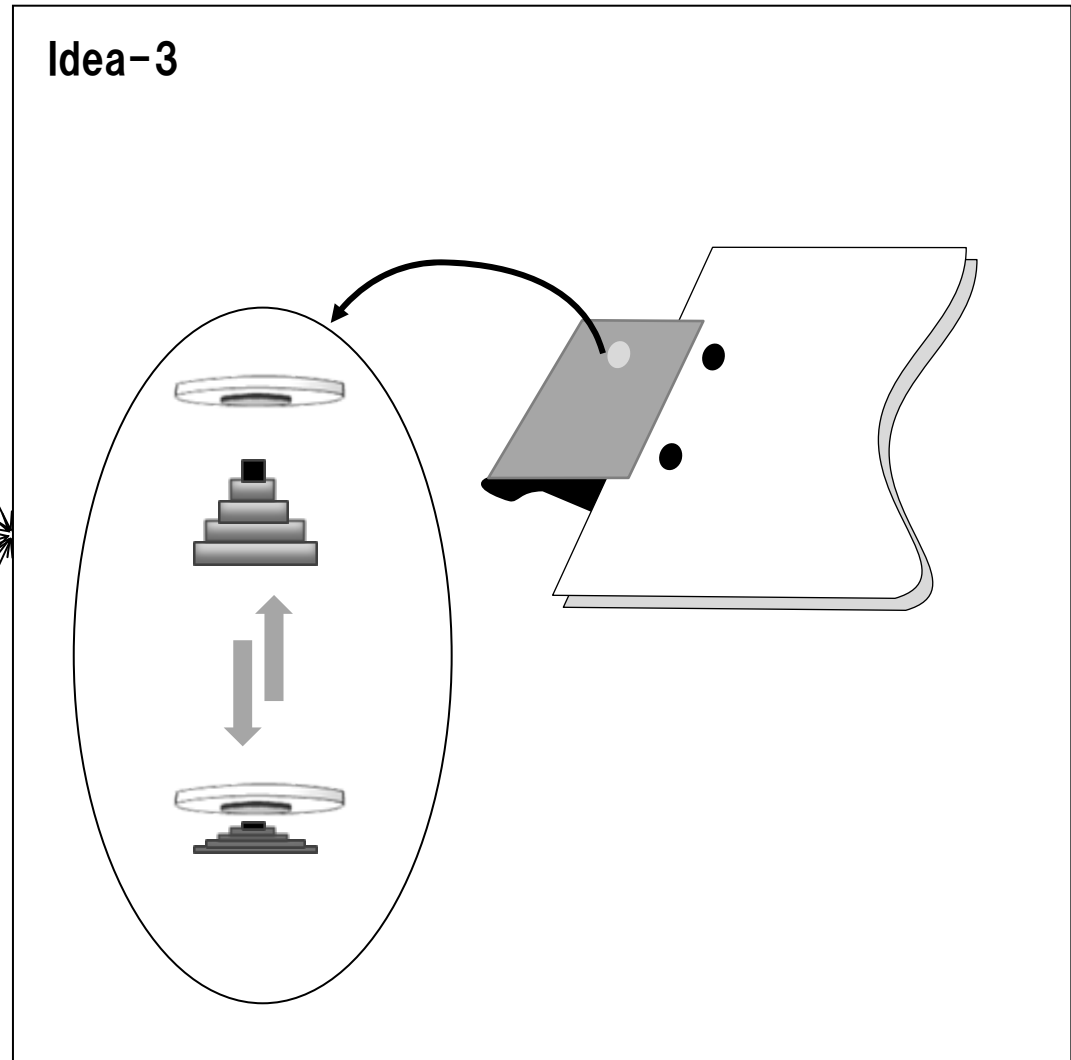


【5-2 Solution Generation Methods】

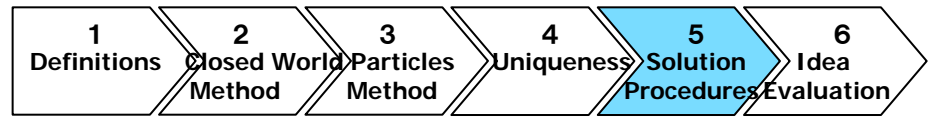
【Secondary Step】 Generation by Solution Combination

- a- i) Combine functionally
- a- iv) Combine structurally

B 1	
	• Fingernail of conical geometry
B 2	
	• arrange by upper fingernail & under suppress tool
B 3	
	• arranges by 1 fingernails.
C 3	
	• Nested fingernail
D 1	
	• Magnet



5. Solution Procedures



【5-2 Solution Generation Methods】

【Secondary Step】 Generation by Solution Combination

- a-I) Combine functionally
- a-II) Combine spatially
- a-iv) Combine structurally

C 1

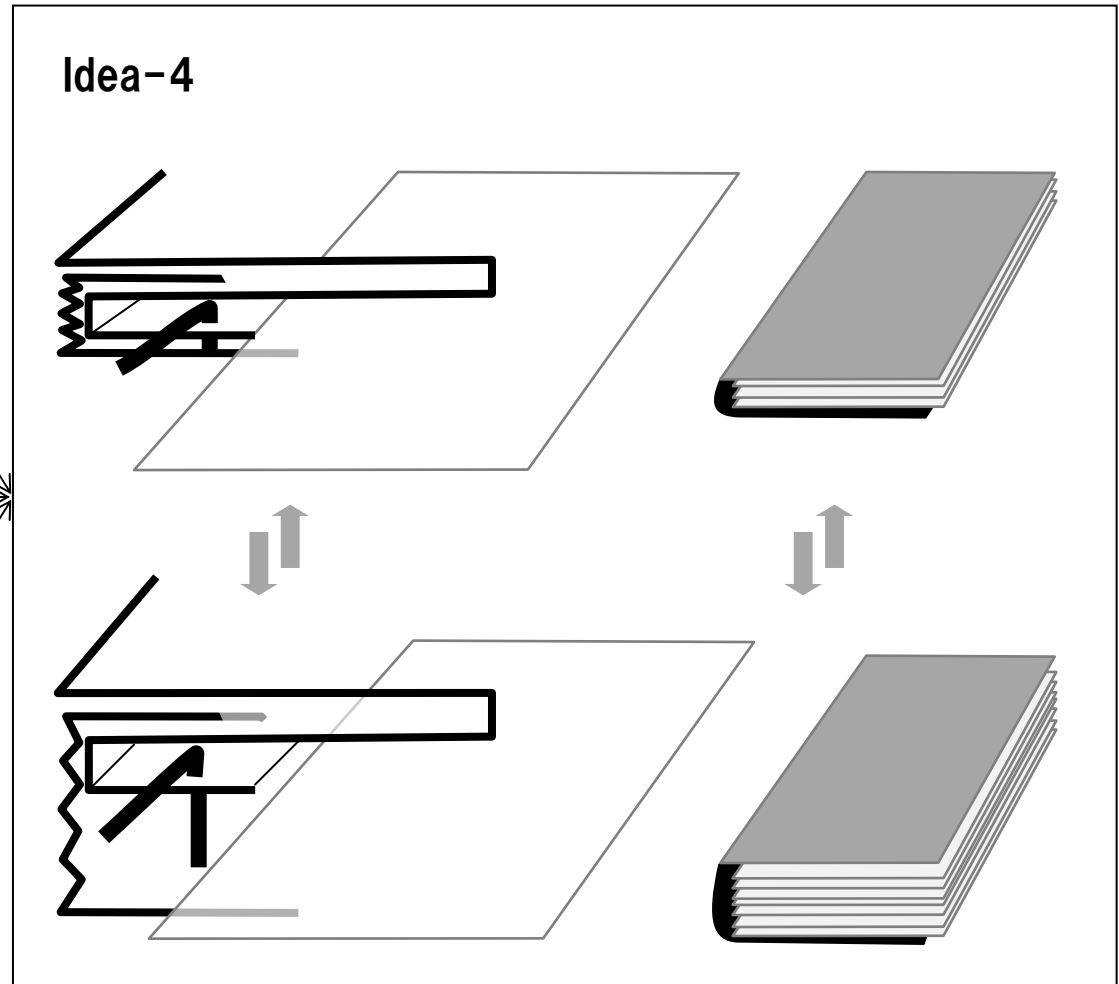
- Bellows
- Spring

C 2

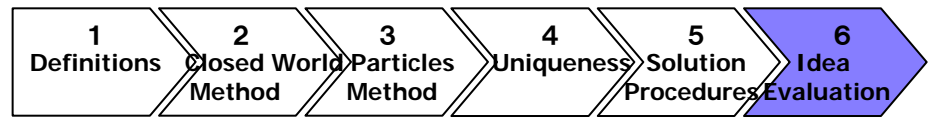
- Nested suppression tool

D4

- expand the area of the suppression tool



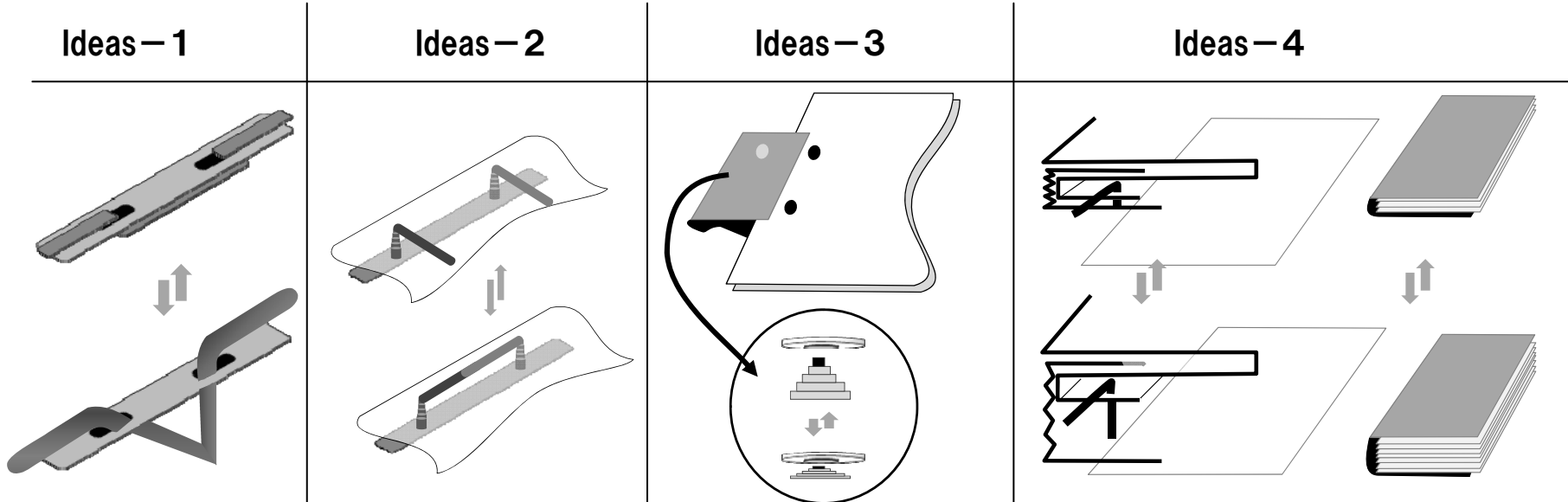
6. Idea Estimation



【6-1 : Decision of evaluation item 】 【6-2 : Evaluation of idea 】

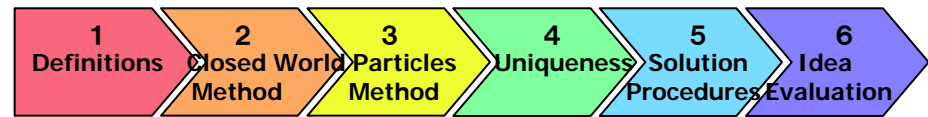
Evaluate the ideas in accordance with the target and the precondition

(The distribution point is assumed to be 1, 2, 3, and 4.)



Evaluation item	Idea1	Idea2	Idea3	Idea4
1. Replacement time :as faster as possible.	3	3	3	2
2. Consideration to easiness to arrange	2	2	3	3
3. flexibility to thickness: thickness: The Min 5mm thickness. (Want:10mm)	2	2	3	4
4. Basic function as a paper fastener (pressing firmly).	3	3	3	3
5. easiness of fingernail to pass	4	3	4	3
Overall Evaluation	14	13	16	15

Summary



1. Introduction of the USIT Approach for the Problem of Paper Fastener

◆ We could have experienced USIT approach by a familiar theme, and have found the effectiveness at the same time. The excellent point of the USIT is to arise naturally the solving point of the problem while focusing there object, attribute, and function and combine them with unique feature of spatial or temporal side.

2. Various solution ideas and conceptual prototypes

◆ Though it was not a purpose to output the best solution but after adopting USIT approach, we could output various solution ideas of Paper fastener

3. New tools for USIT approach

◆ Various tools for improving USIT method are bone and the effectiveness was able to be shared among members

- ★ Procedure according to a USIT Workbook
- ★ Analysis by Time and Space Double axis
- ★ Smart Personified object (Personification for Object)